



Reg. No. :

--	--	--	--	--	--	--	--	--	--	--	--	--	--	--	--	--	--	--	--

Question Paper Code : 40900

B.E./B.Tech. DEGREE EXAMINATION, APRIL/MAY 2018

Third Semester

Computer Science and Engineering

CS6301 – PROGRAMMING AND DATA STRUCTURES – II

(Common to Information Technology)

(Regulations 2013)

Time : Three Hours

Maximum : 100 Marks

Answer ALL questions

PART – A

(10×2=20 Marks)

1. What are the concepts in C++ that makes it Object Oriented ?
2. Write the syntax and uses of 'this pointer'.
3. Can we make a class constructor *virtual* in C++ to create polymorphic objects ?
4. How to allocate and deallocate dynamic memory ?
5. What are the main advantages of exception handling over traditional error handling ?
6. Write a sample for arithmetic binary functions.
7. Give examples for linear and non linear data structures.
8. State the Heap Order Property.
9. What are the representation of graphs ?
10. What are the applications of graph algorithms ?

PART – B

(5×13=65 Marks)

11. a) Write code in C++ to show that static members are shared among all objects. And explain. **(13)**

(OR)



- b) i) Consider pointer notation for the two-dimensional numeric arrays and with the following declaration fill up the table below for all values in 2D array.

(7+6)

```
int nums [2] [3] = { {16, 18, 20}, {25, 26, 27} };
```

Pointer notation	Array notation	Value
....

- ii) Write the output of the following program.

```
int main ()
```

```
{
```

```
    char arr [5] [7] [6];
```

```
    char (*p) [5] [7] [6] = &arr;
```

```
    printf ("%d\n", (&arr + 1) - &arr);
```

```
    printf ("%d\n", (char*) (&arr + 1) - (char*) &arr);
```

```
    printf ("%d\n", (unsigned) (arr + 1) - (unsigned) arr);
```

```
    printf ("%d\n", (unsigned) (p + 1) - (unsigned)p);
```

```
    return 0;
```

```
}
```

12. a) Write minimum of 30 overloaded operators and all the non-overloaded operators in C++ and write C++ code to overload post and pre increment operators.

(5+8)

(OR)

- b) Explain Dynamic Memory Allocation in C++ with examples for arrays and objects.

(13)

13. a) List standard exceptions in C++ and show how to define user defined exception with suitable example.

(6+7)

(OR)

- b) List the functions used with STL Lists. And use these functions to demonstrate STL list.

(6+7)

14. a) Explain amortized analysis and its types in detail.

(13)

(OR)

- b) Write pseudocode to perform rotation operation in splay tree.

(13)



15. a) Write Kruskal's and Prim's (starts at F) Minimum Spanning Tree Algorithm and apply both techniques on the graph given below in Fig. 1. Can Prim's and Kruskal's algorithm yield different minimum spanning trees? Explain why or why not. (13)

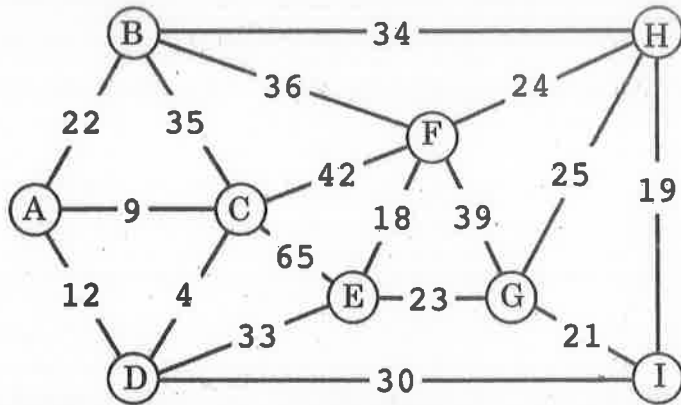

Fig. 1

(OR)

- b) Write algorithm to find shortest path using Dijkstra's method and apply the same to estimate shortest path from the graph given in Fig. 2. (13)

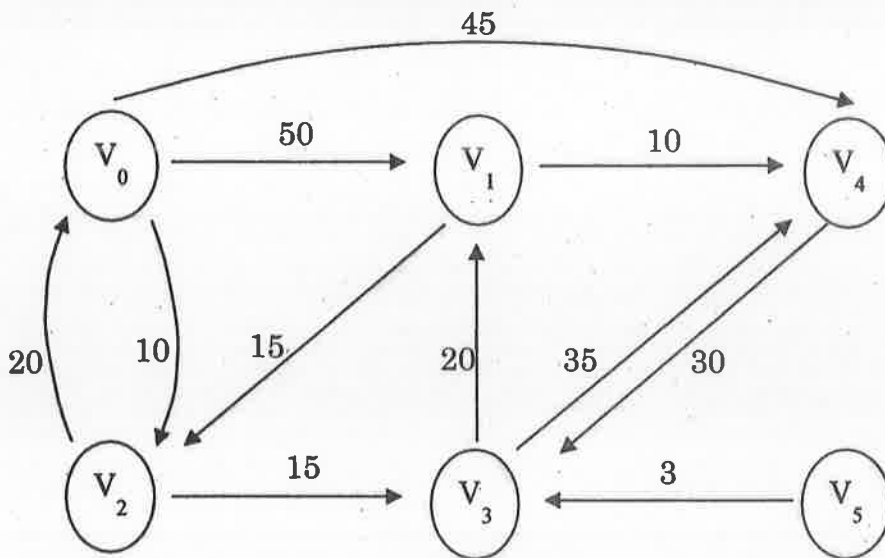

Fig. 2

PART - C

(1×15=15 Marks)

16. a) Write generic code in C++ to implement AVL tree insertion. And show the result of inserting 2, 1, 4, 5, 9, 3, 6, 7 into an initially empty AVL tree. (10+5)
- (OR)
- b) Write a C++ code using function with multiple parametrs to perform recursive binary search on a linear array. (15)

